



ESCAPE RECESSED

Escape represents a milestone in emergency lighting combining all of the components in a single small luminaire. Its flexible circuit technology enables a complete solution to be integrated in an extremely compact housing. The user interchangeable optics provide maximum flexibility covering a wide range of emergency applications. The combination with an energy-optimised lithium iron phosphate (LiFePO₄) battery with a proven 8 years design life results in a high-quality product. A clever mounting concept saves valuable time during installation.

Features and Benefits

- Up to 217 lm (dependant on lens used)
- 5 year warranty on electronic components
- 3 year warranty on batteries
- IP Rating: IP20
- Complete solution ready to apply with integrated electronics, LED module, heat sink, optics and battery
- Includes click-in multi-lens option for anti-panic, escape route and spot illumination
- Emergency lighting function for manual testing, Self-Test and Dali
- Small size ceiling hole, 40 - 43 mm diameter, 80 mm height
- Very low stand-by power consumption
- Maintained and non-maintained variants
- Black Box technology - Retains whole life performance history

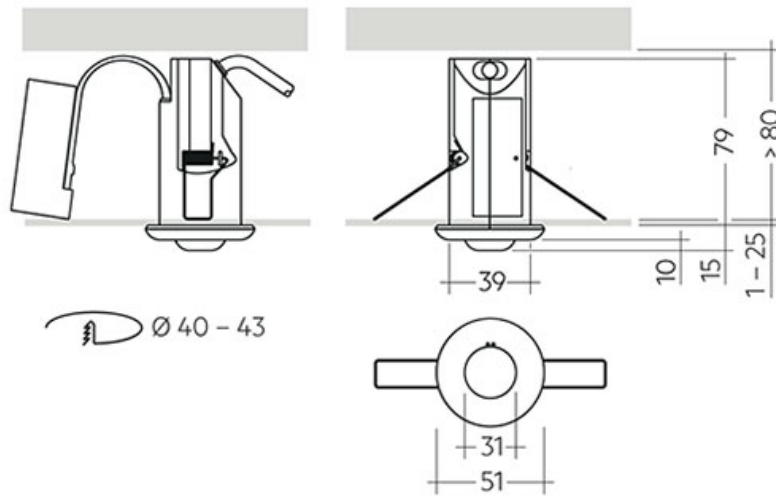

Part Number	Rated duration (h)	Operation	Number of cells	Output power (W)
ESCAPE2WNM	3	Non-maintained	2	1.50
ESCAPE2WNM-STEST	3	Non-maintained Self-Test	2	1.50
ESCAPE2WNM-PRO	3	Non-maintained EMPRO	2	1.50

*Available as Maintained